

Heavy Duty Straight Line Wipers Odin Control System

USER MANUAL

Contents

1	Introduction	4
1.1	Purpose of manual	4
1.2	Marking of equipment	5
1.3	Symbols	6
1.4	Common abbreviations	6
2	Introduction	7
2.1	General description	7
3	Main data	8
3.1	Dimensions	8
3.2	Technical data	10
3.2.2	Power supply	10
3.2.3	Power consumption	10
3.2.4	Weights	10
4	Technical description	11
4.1	Functional description	11
4.1.1	Wiper unit	11
4.1.2	Wiper arms	12
4.1.3	Odin control panels	14
4.1.4	Odin electronic control module (ecm)	15
4.2	Typical installations	18
4.3	Water spray system (option)	19
4.3.1	Air purge system	20
5	Installation procedure	21
5.1	Location of wiper unit brackets	21
5.2	Bulkhead penetration	22
5.3	Wiper casing	22
5.4	Cable connections	23
5.4.1	Wiper unit cable connecton	23
5.4.2	Electronic control module(ecm) cable connection	24
5.4.3	Wiper control panel	25

6	System operation	28
6.1	Wiper control panel	28
6.1.1	Wiper speed settings	28
6.1.2	Off/resume function (main switch)	29
6.1.3	Heater function	29
6.1.4	Water spray and air purge function	29
6.1.5	Night mode	29
7	Spare parts	30
8	Warranty	32
9	Trouble shooting	32



Straight line wipers

1 Introduction

1.1 Purpose of manual

The purpose of this manual is to provide guidance for installation and operation of Decca Straight Line Wipers controlled with the Odin Control system, as supplied by Decca Wiper Systems AS.

The manual is intended to give technical information to understand the functions and features of the Decca Wiper Systems and to be able to operate the system, together with installation, commissioning and maintenance information.

The manual shall also be used as a textbook for training of crew, and should be read and understood before operation of the wiper system.

Changes occurring since the last issue of the manual are marked with vertical black lines in left margin.

1.2 Marking of Equipment

The wiper unit is identified with a label positioned on the back side of the wiper casing. An additional, similar label is positioned in a more protected location behind the wiper motor cover.

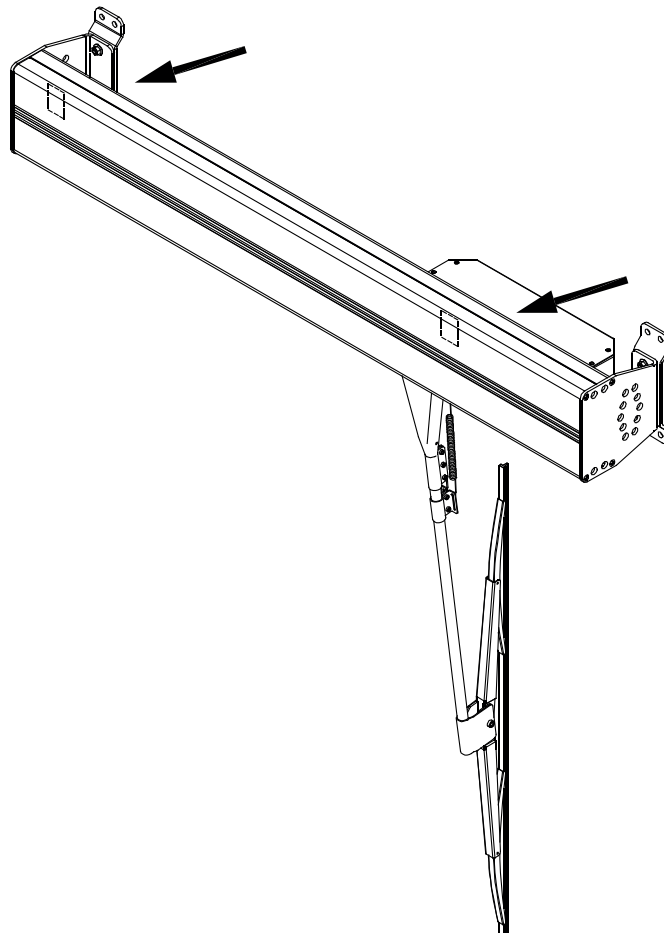

Figure 1 - Label Locations on wiper unit

The product label contains a serial number and technical information about the wiper unit. For service and spare part orders, always refer to the information listed on the product label.

1.3 Symbols



The **NOTE** symbol gives clarifying information or special instructions which are crucial for the equipment or to the operation performed.



The **WARNING** symbol gives clarifying information or special instructions where personal injuries or damage to the equipment can occur.

1.4 Common abbreviations

<i>Abbreviation</i>		<i>Explanation</i>
mm	-	millimetres
"	-	inches
kg	-	kilogram
ECM	-	Electronic Control Module

2 Introduction

2.1 General description

Modern shipbuilding takes full account of visibility requirements. Larger wheelhouses with an omnidirectional view are part of this trend. As a result, there is an increase in window area that must be kept clear in all weather conditions. Decca straight line wipers are designed to meet these demands with reliable and efficient operation in heavy rain, storm conditions, sleet and even snow.

With unique technical design features and built with only high quality materials, Decca wipers provide a reliable wiper operation in extreme weather conditions.

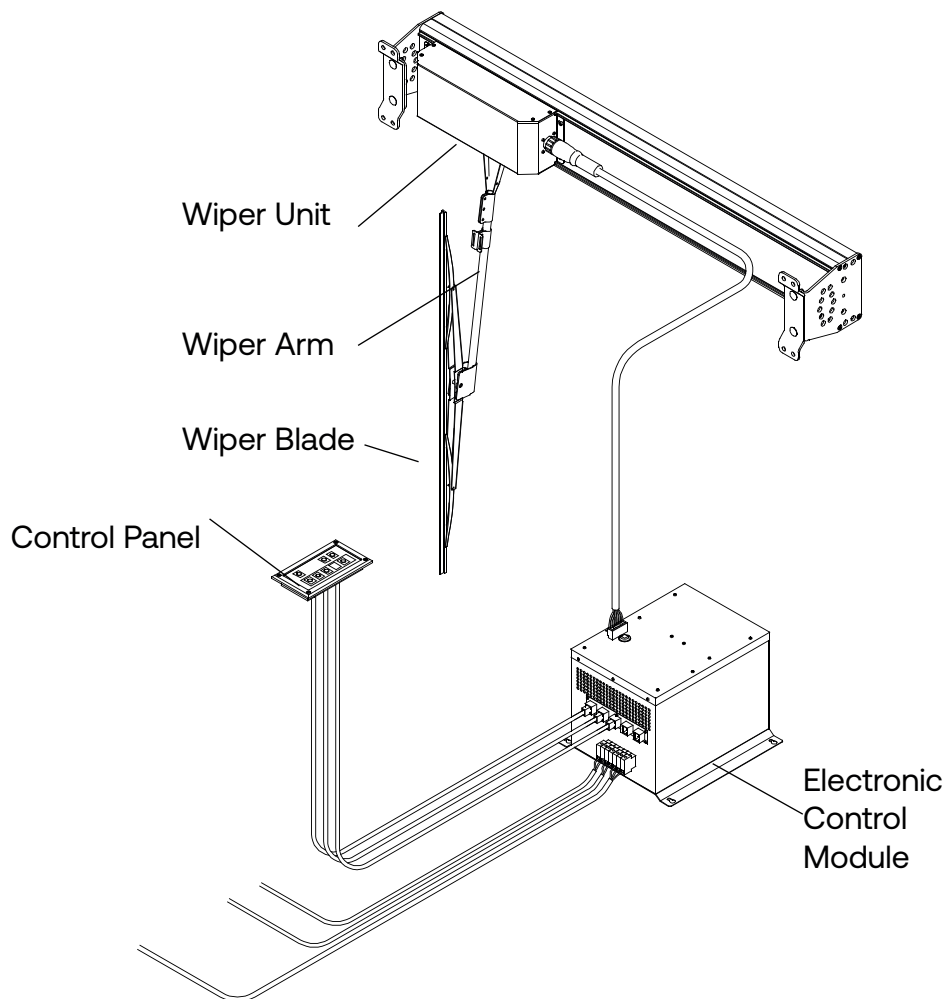

Figure 2 - Example of wiper system

3 Main data

3.1 Dimensions

The wiper units are delivered in 50mm (1,96") increment stroke lengths ranging from 500mm (16,69") to 3000mm (118,11"). The wiper blades range from 500mm (19,68") to 1000mm (39,37"), and the wiper arm length can be adjusted to fit the window site.

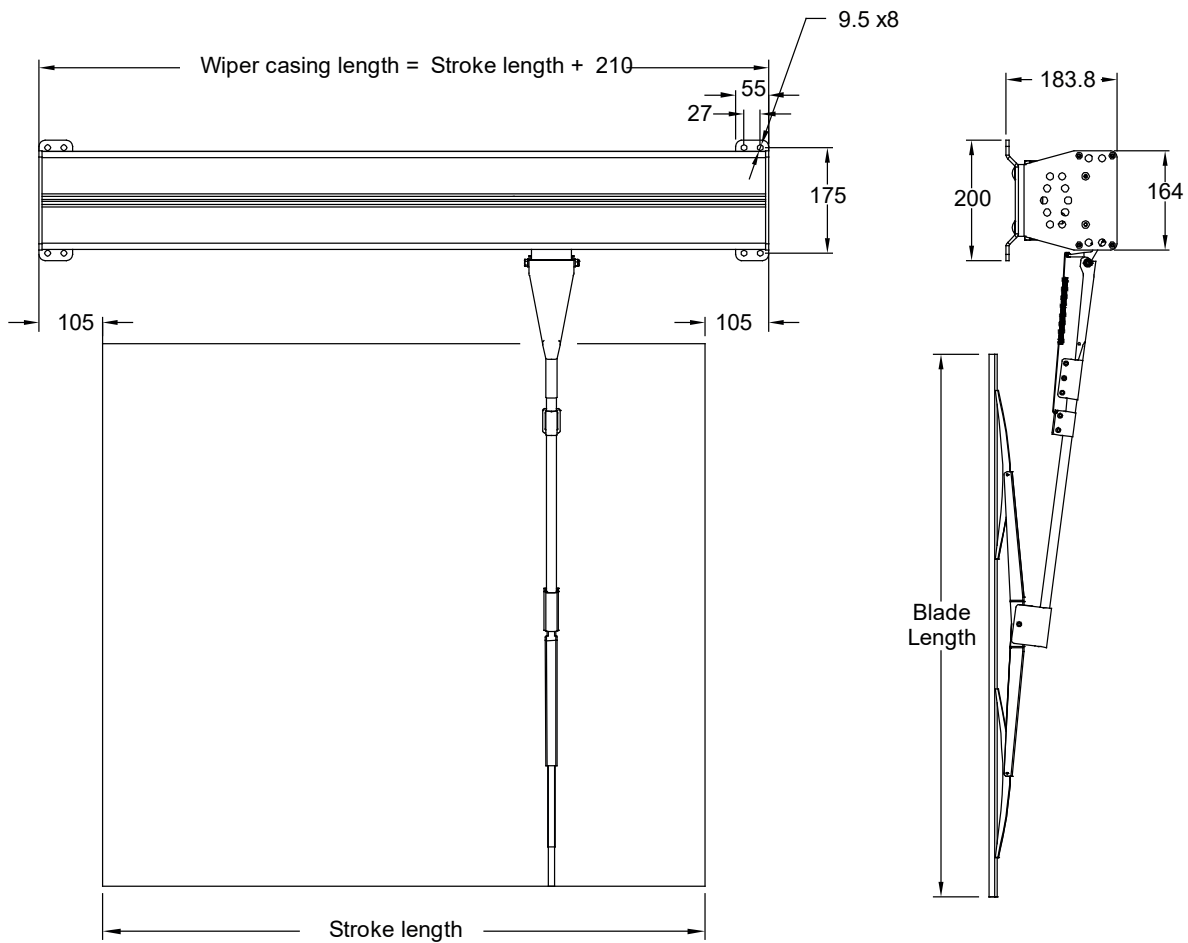
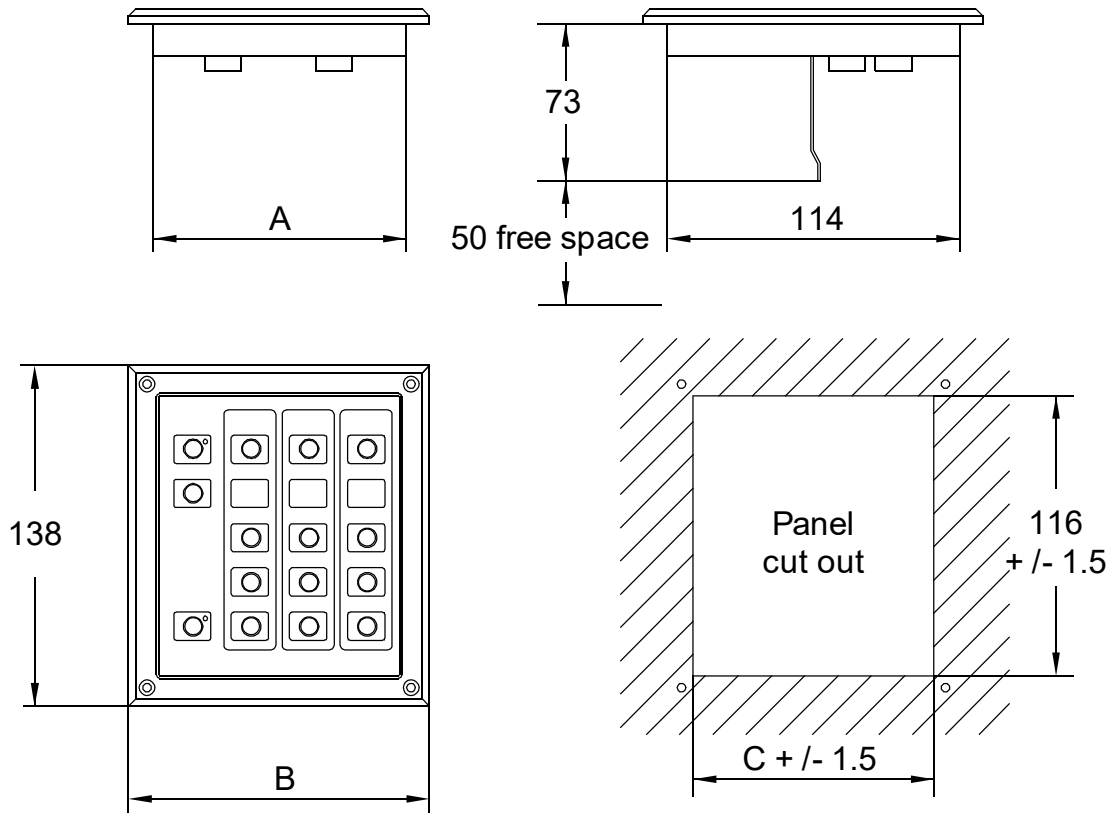

Figure 3 - Wiper Unit Dimensions (all measurements in mm)

The Odin Control Panel is available in five versions, featuring control of one to five wiper groups. See figure below for physical dimensions.



Model	A	B	C
12183010	49	80,5	51
12183020	73	103.4	75
12183030	96	126.9	98
12183040	119	150.4	121
12183050	151	182.5	153

Figure 4 - Odin Control Panel dimensions - Three Group Panel (1283030) illustrated (all measurements in mm)

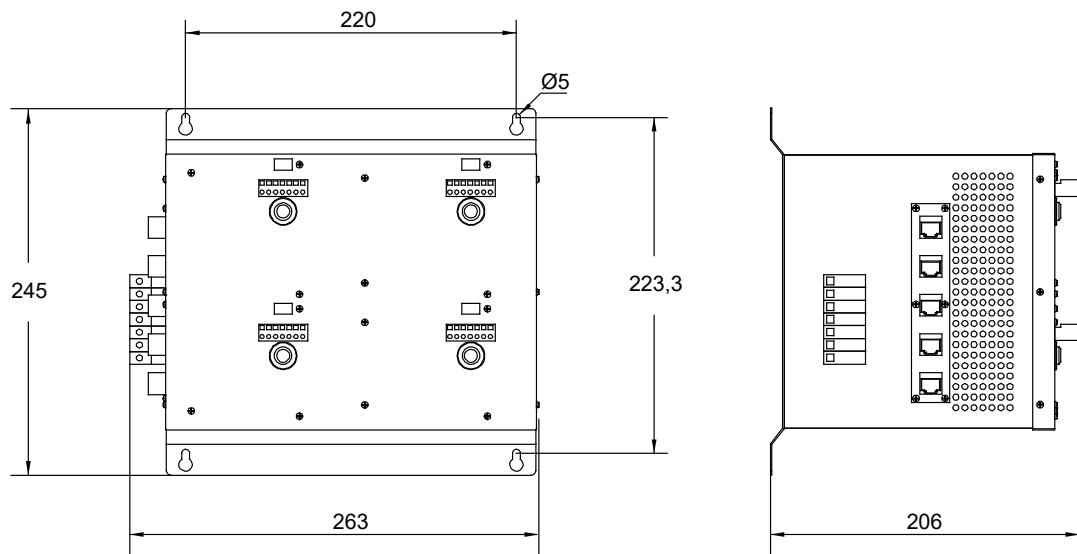

Figure 5 - Electronic Control Module (all measurements in mm)

3.2 Technical data

3.2.2 Power supply

Power supply voltages: 110VAC Single Phase, 220VAC Single Phase or 24V DC

3.2.3 Power consumption

Power consumption: 120W for motor and 75W for heater element
Heater elements are equipped on 110VAC and 220VAC systems only

3.2.4 Weights

Wiper Unit (Single wiper 500mm stroke):	11,0kg	(24,2lb)	(387,2oz)
Additional weight pr. 100mm stroke:	0,5kg	(1,1lb)	(17,6oz)
Control Panel 12183010:	0,500kg	(1,10lb)	(17,6oz)
Control Panel 12183020:	0,625kg	(1,38lb)	(21,0oz)
Control Panel 12183030:	0,750kg	(1,65lb)	(26,4oz)
Control Panel 12183040:	0,875kg	(1,93lb)	(31,8oz)
Control Panel 12183050:	1,000kg	(2,20lb)	(35,2oz)
Electronic Control Module(ECM), one wiper:	2,5kg	(5,5lb)	(87,0oz)
Electronic Control Module(ECM), two wipers:	3,0kg	(6,6lb)	(104,6oz)
Electronic Control Module(ECM), three wipers:	3,5kg	(7,7lb)	(122,2oz)
Electronic Control Module(ECM), four wipers:	4,0kg	(8,8lb)	(139,8oz)

4 Technical description

4.1 Functional description

4.1.1 Wiper Unit

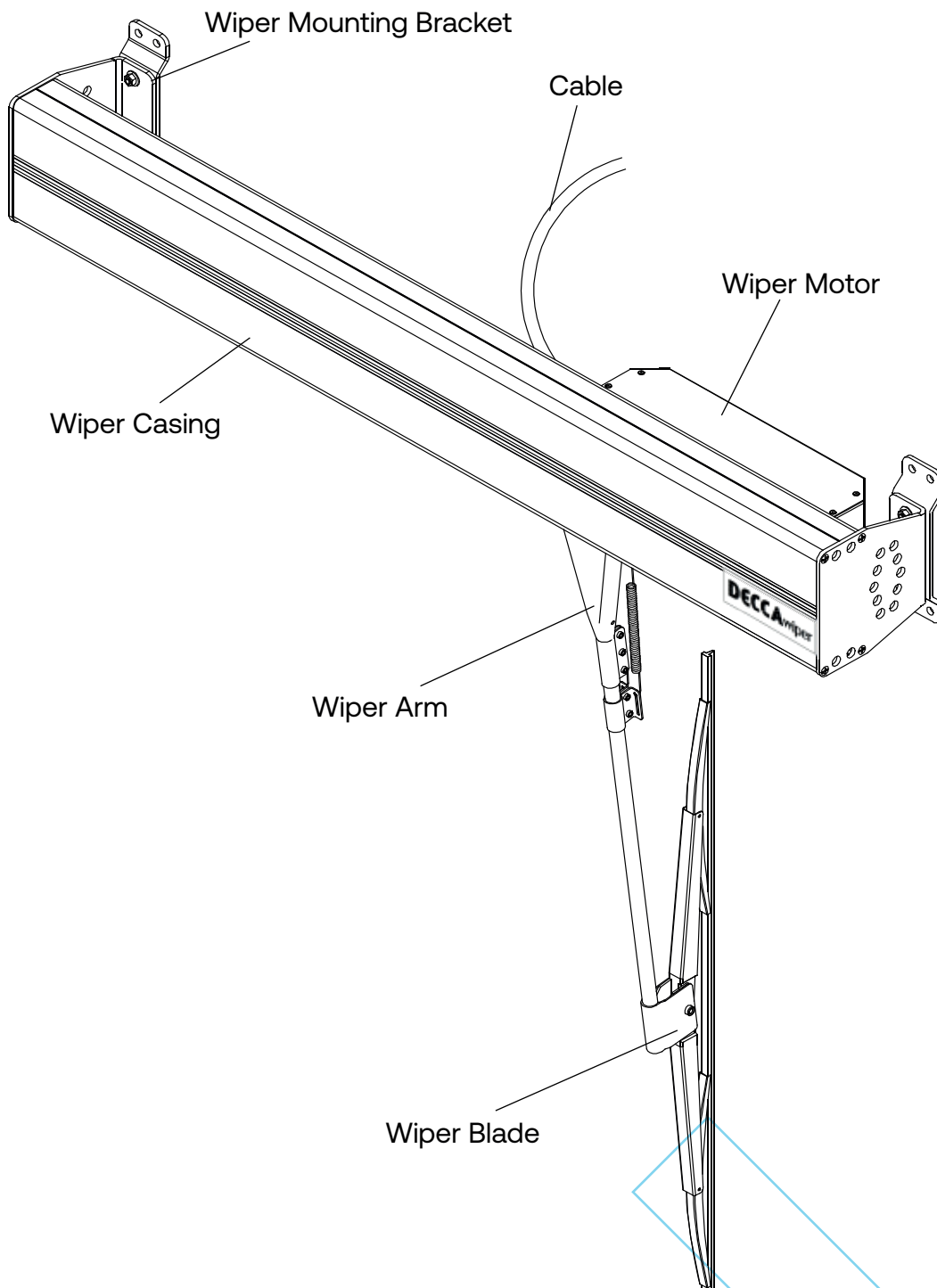

Figure 6 - Wiper Unit

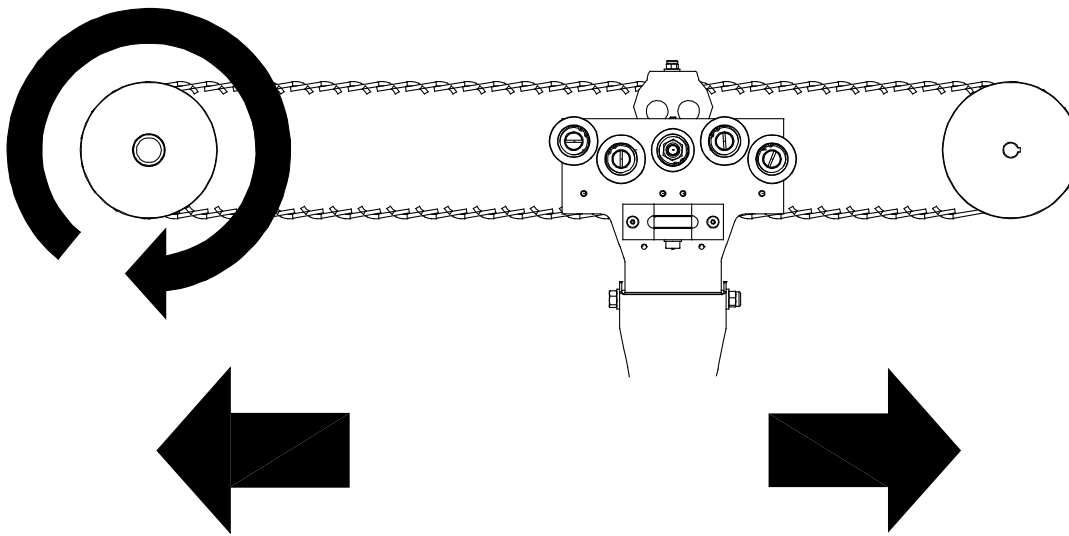

Figure 7 - Wiper Function - as viewed from front of wiper unit

4.1.2 Wiper Arms

The arm is supplied in full length, and is cut to appropriate length on site. The three M4 DIN912 bolts on the upper part of the arm assy secure the arm in correct position. This mechanism allows +/- 30mm fine adjustment of the arm length.

The wiper arm features step less spring tension adjustment by means of two springs and a spring tension clamp that is secured by two M4 DIN912 bolts.

The spring tension clamp should be positioned so that the wiper blade is pressed against the window with a force of approximately 2 kg (4 lb). See figure 9 for practical advice on spring tension adjustment.

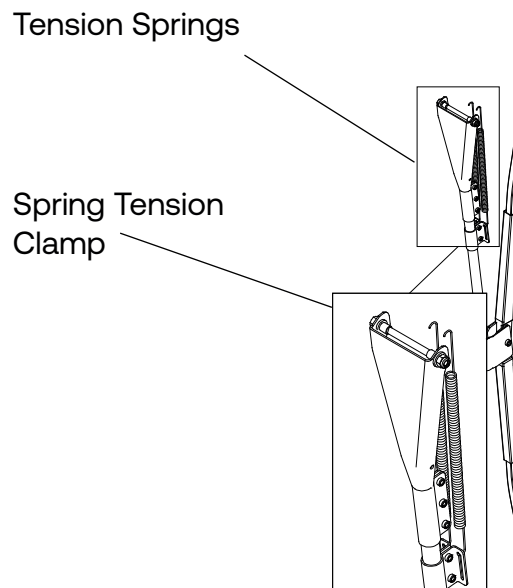
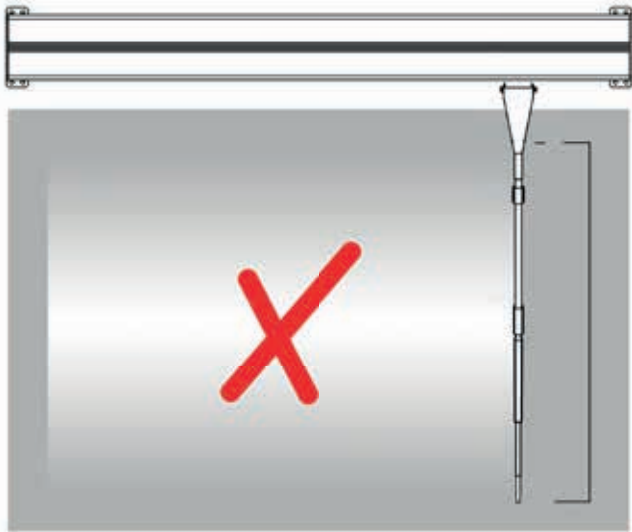
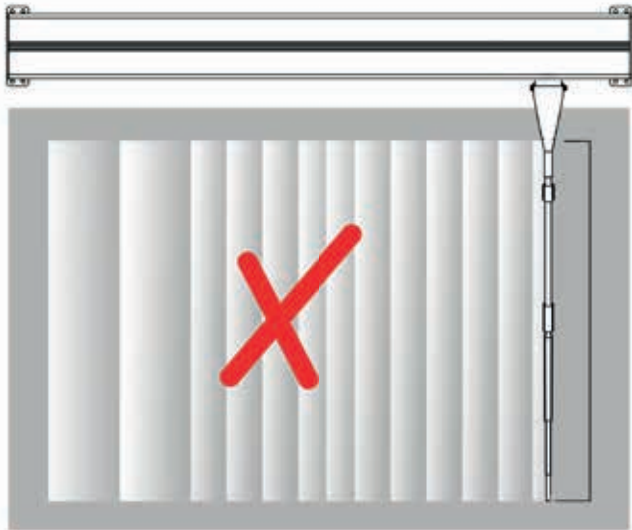

Figure 8 - Wiper Arm



Tension too low



Tension too high

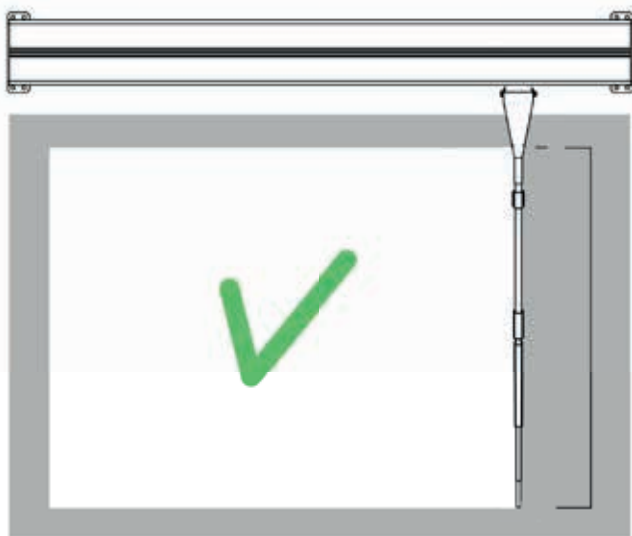

Tension correctly adjusted

Figure 9 - Wiper Tension Adjustment

4.1.3 Odin Control Panels

The wiper system is operated from the control panel, typically mounted with good access from the operator's position. From the control panel the wiper/groups are switched on and off, and the wiper speed and intermittent settings are adjusted.

The Odin control panel is available in five versions, controlling from one to five different wipers/wiper groups.



Figure 10 - Odin Control Panel (12183030 illustrated)

4.1.4 Odin Electronic Control Module (ECM)

The ECM distributes control signals to the wiper units and the optional water spray system, with input from the control panel. Each ECM controls up to four wipers and two solenoid valves.

The ECM has a protection grade IP20, and should be located in a well vented area where it is not exposed to excess dust or moisture. Allow at least 50mm free space on all sides.



The ECM should be placed where there is good access for future service. Placing the ECM above ceiling panels or below floor panels is therefore not recommended.

Consult with your Decca supplier for practical advice and project specific solutions.

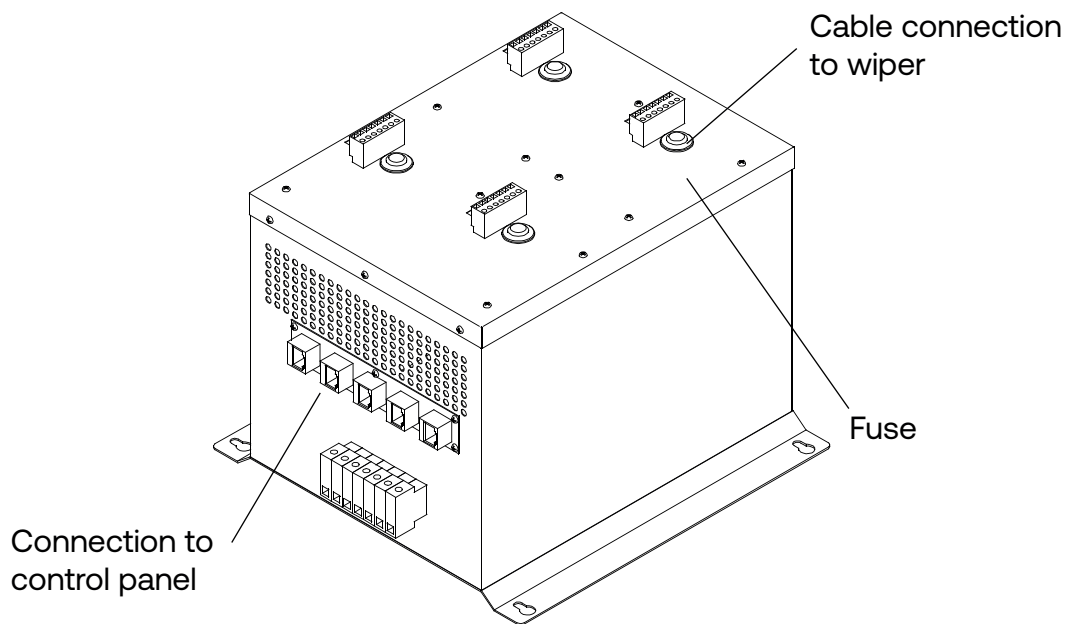

Figure 11 - Odin Electronic Control Module

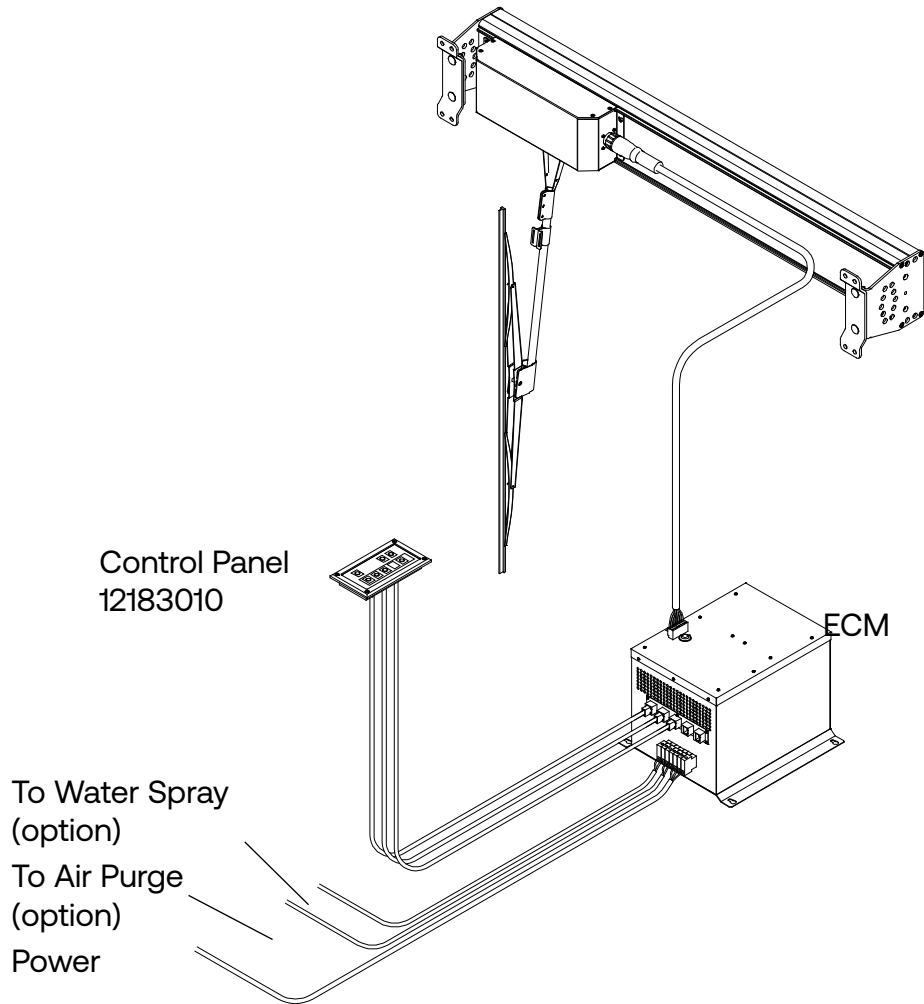

Figure 12 - Typical set up, one Wiper/Group

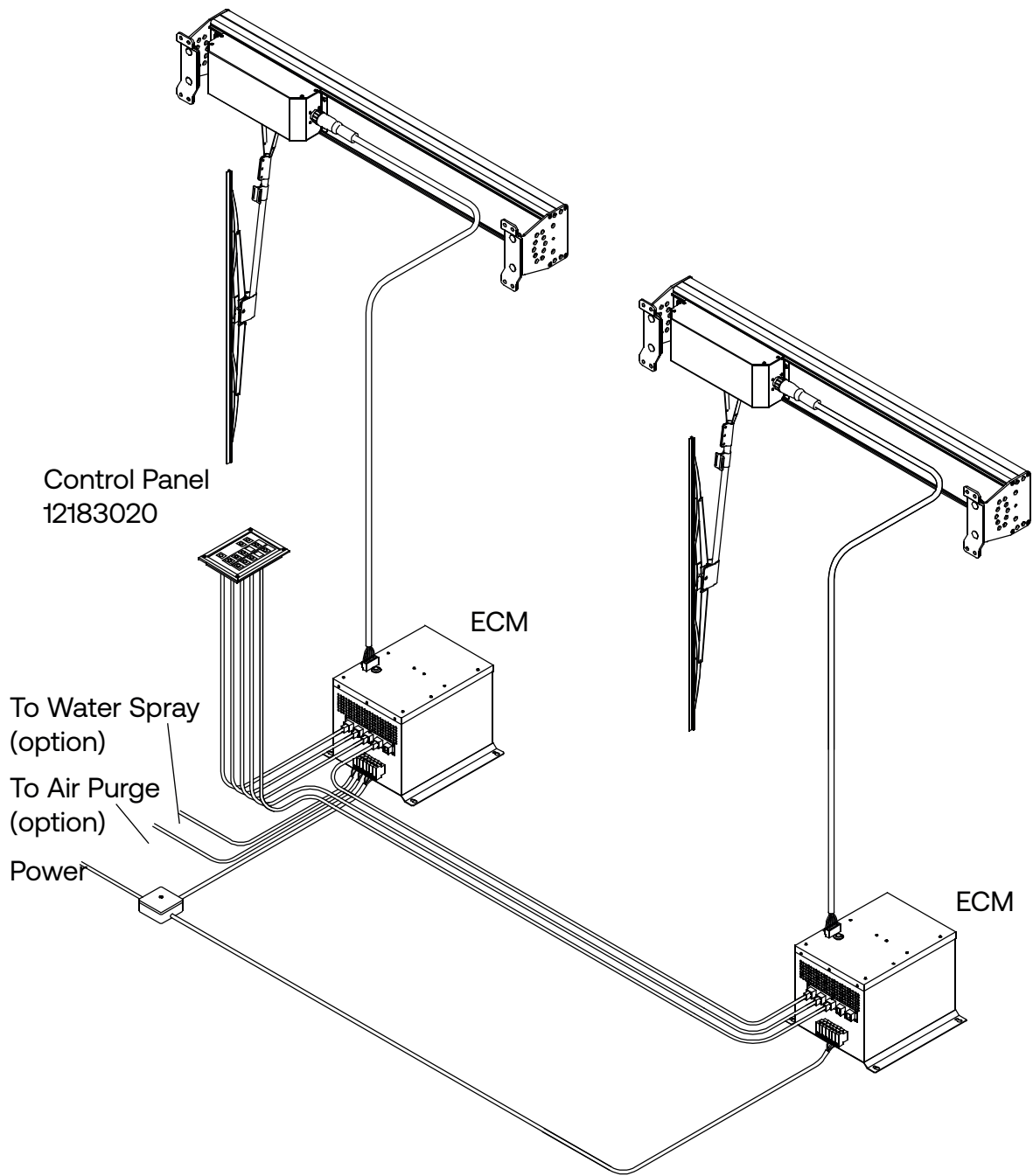

Figure 13 - Two Wipers/Groups, separate Operation

4.2 Typical installations

A standard wiper installation features a single arm wiper unit that is mounted above or below the window frame. See examples in figure 14.

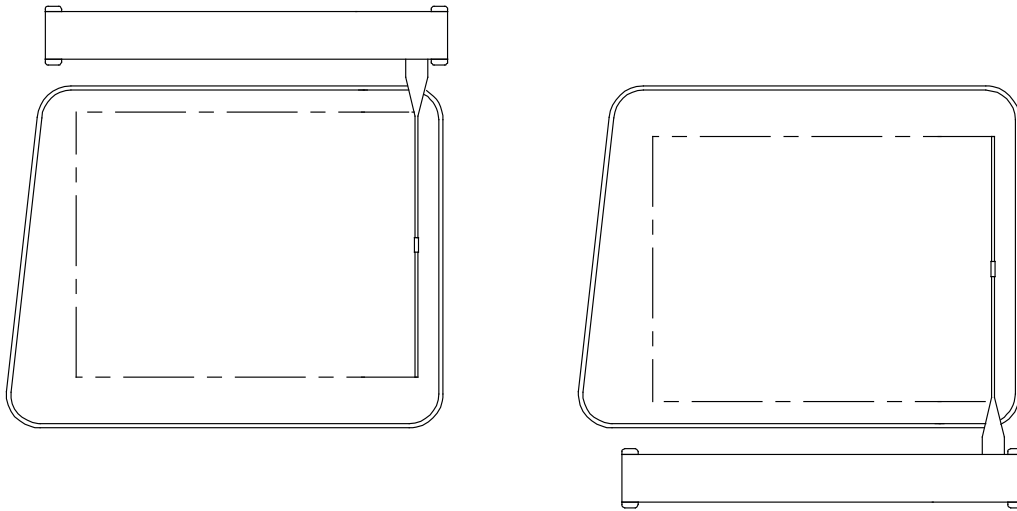

Figure 14 - Single Wiper Installation Layouts

Taller windows require two wipers to ensure maximum visibility, where one wiper unit covers the upper part and the other covers the lower part of the window. See example in figure 15, left side. Optionally, the wiper unit can be supplied with two wiper arms. The dual arm wiper unit can either be configured to cover one large window, or two smaller adjacent windows. See examples in figure 15, right side.

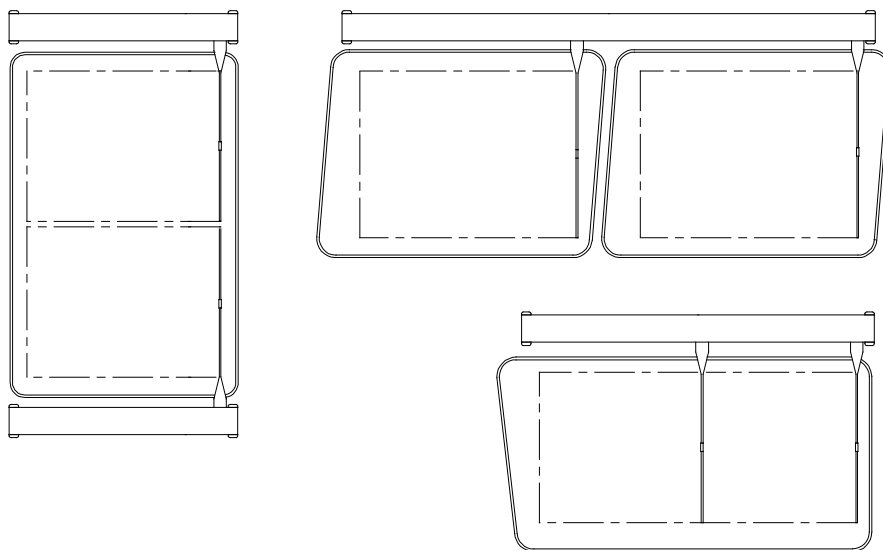

Figure 15 - Dual Wiper Installation Layouts

4.3 Water Spray System (option)

Decca wipers can be equipped with an optional water spray system that consists of 12mm OD piping and nozzles, all in stainless steel (316L). The water spray system can be installed onto the wiper mounting brackets, or directly onto the bulkhead.

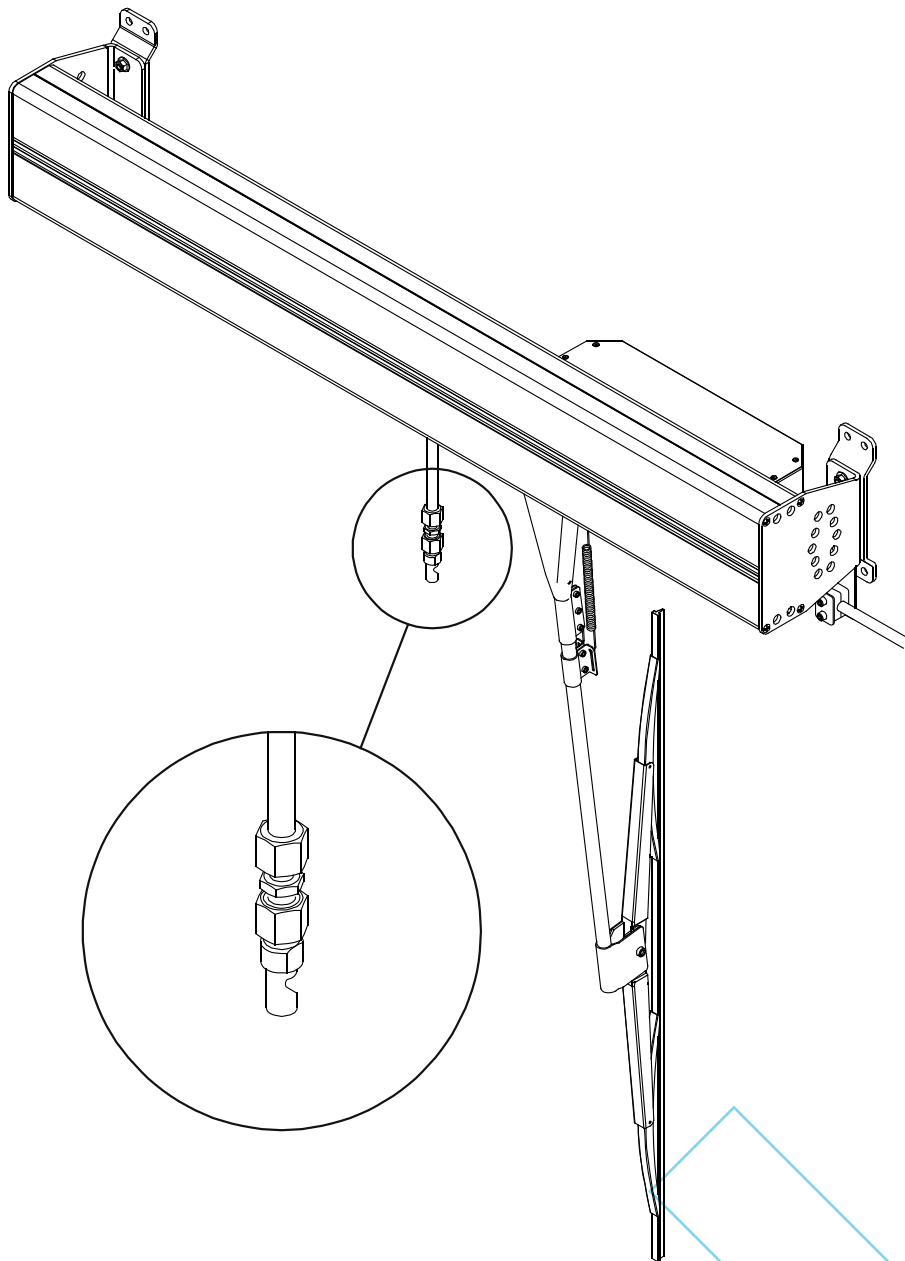

Figure 16 - Water Spray System

4.3.1 Air Purge System

To prevent trapped water from freezing inside the water spray piping at sub zero temperatures, the Decca wipers can be equipped with an air purge system. The system comprises two solenoid valves and an electronic valve controller with a programmable timer function incorporated in the ECM. Air is supplied from the ship's compressed air system.

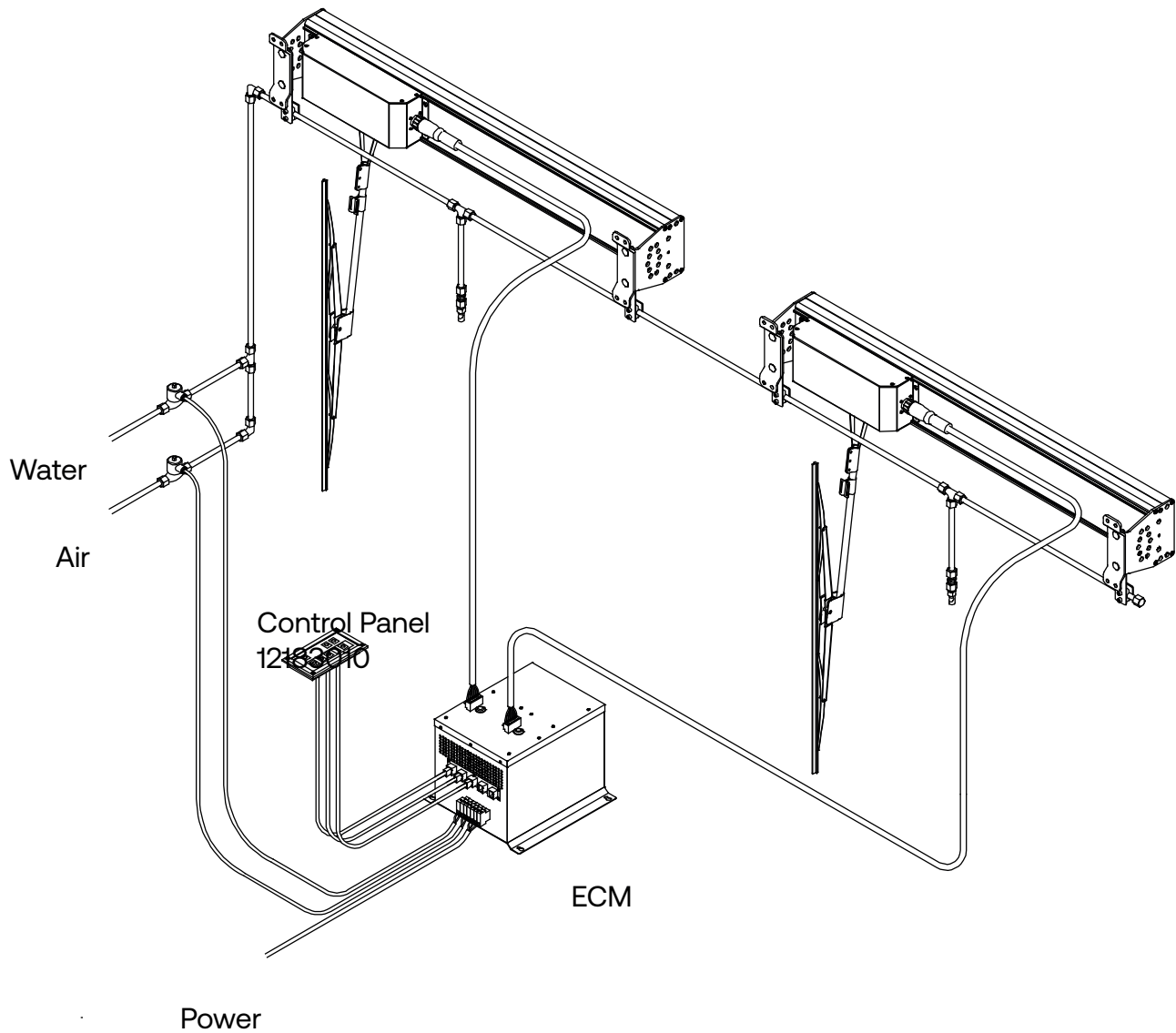

Figure 17 - Water Spray System with Air Purge

5 Installation procedure

5.1 Location of Wiper unit brackets

The wiper unit is equipped with two fixing brackets. The brackets can either be welded or bolted to the bulkhead. Note that the standard brackets are made of aluminium, but mild steel brackets can be ordered as an option. Check the distance between the mounting holes on the end covers of the wiper unit compared with measurements given in Figure 18. The wiper casing should be placed as close to the window frame as possible. Please consult your Decca supplier for project specific CAD drawings.

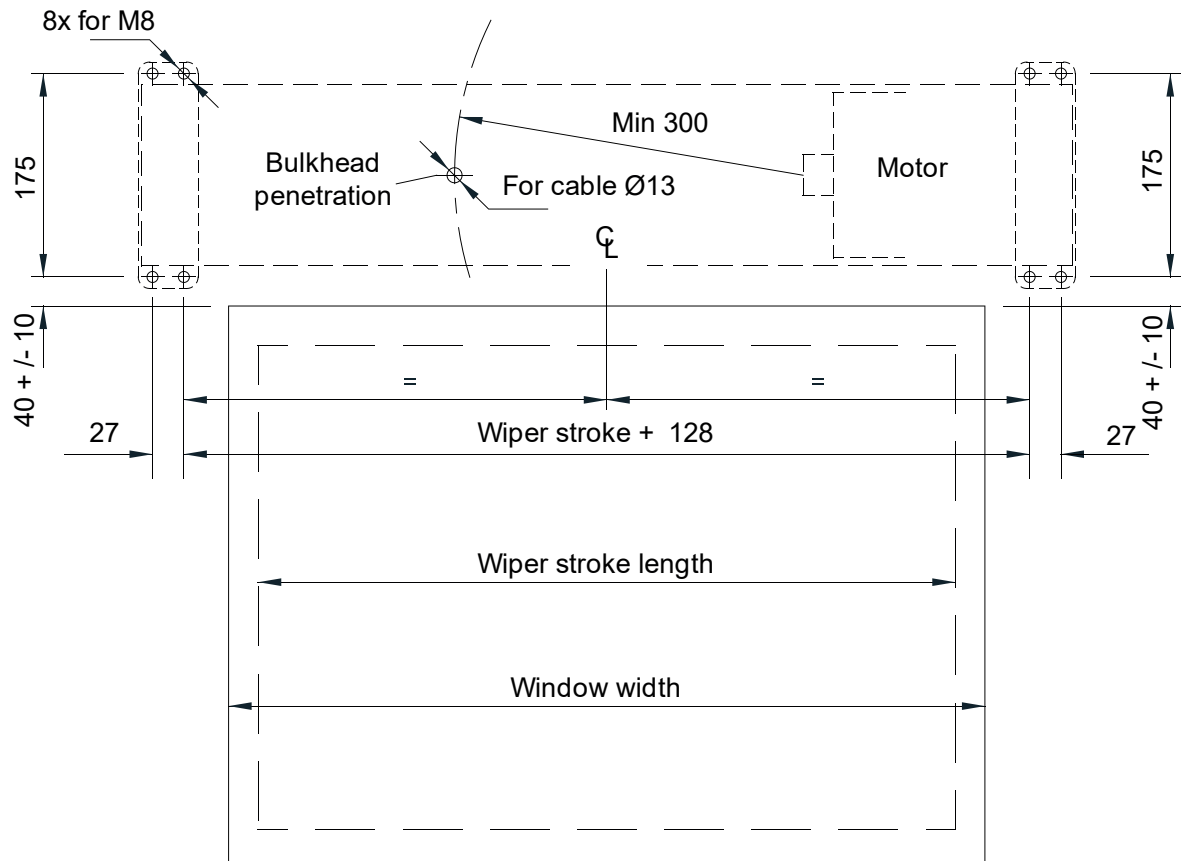

Figure 18 - Wiper Unit Footprint (all measurements in mm)

5.2 Bulkhead penetration

It is important to minimize the tension on the cable and the connector. In order to obtain an optimal location of the bulkhead penetration the hole should be drilled according to the dimension given in figure 19. The cable has an OD of 13mm. The cable gland for bulkhead penetration is not supplied, and must therefore be sourced by installer.



**Avoid sharp bends or edges, the minimum cable bending radius is 75mm.
Protect the connectors from water during installation**

5.3 Wiper Casing

The wiper unit is mounted to the brackets after installation of cable. The wiper unit is bolted to the brackets using carriage bolts for easy fitting and removal, secured with washers and self locking nuts.

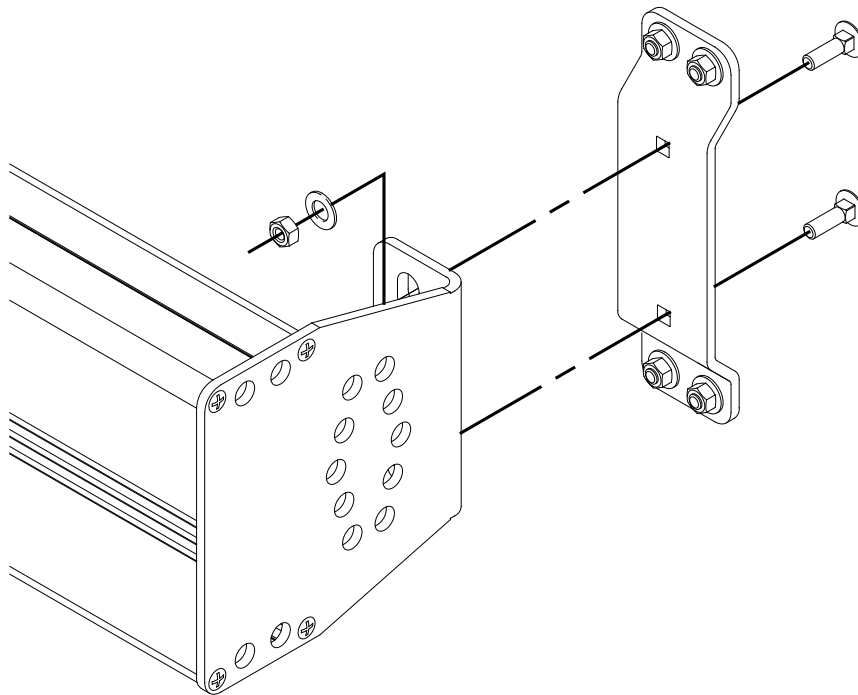

Figure 19 - Wiper Casing Mounting

5.4 Cable connections

5.4.1 Wiper Unit Cable Connector

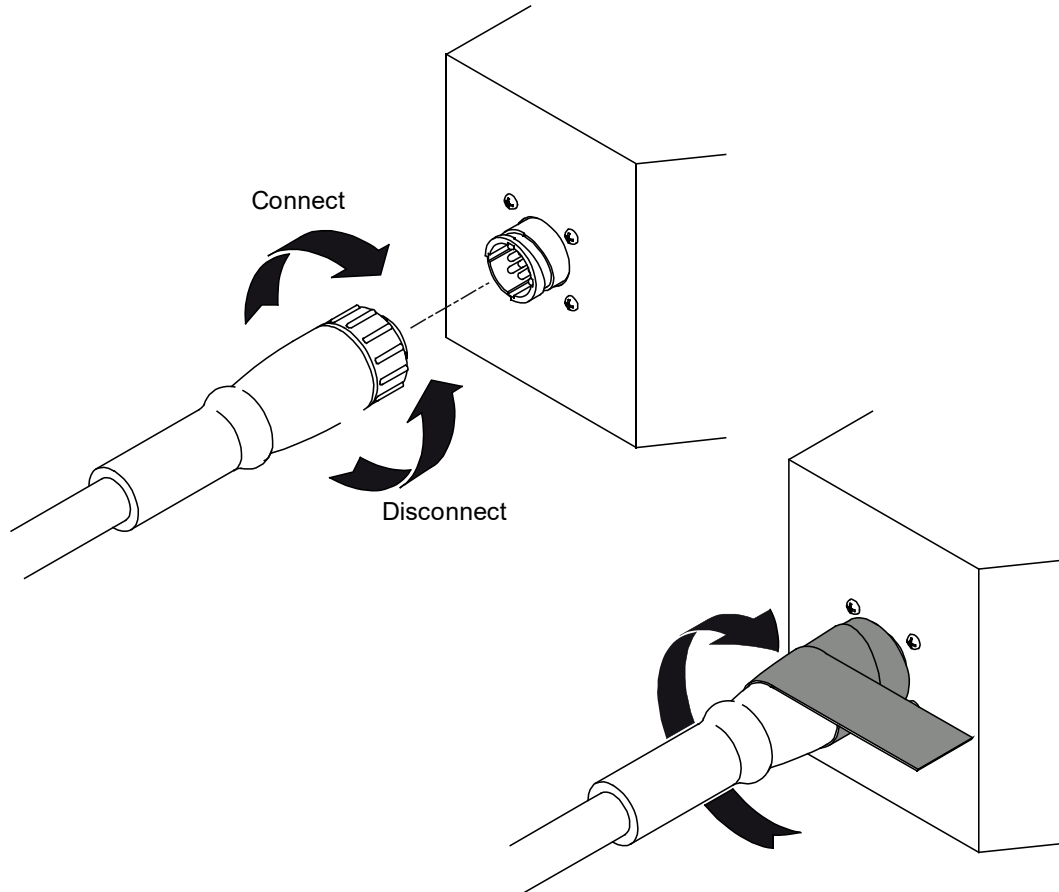

Figure 20 - Cable Connection

Rotate the cable connector to enter the guides in the mating connector. Secure by twisting the outer lock ring clockwise until it clicks into locked position. To form a waterproof connection, tape the connection with self-healing tape: Scotch® Professional Grade Silicone Rubber Tape #70, or similar.



Always make sure that power is switched off before doing any kind of maintenance to the electric circuits



The cable connector should only be twisted by hand. Use of tools and excessive force will damage the connector

5.4.2 Electronic Control Module(ECM) Cable Connection

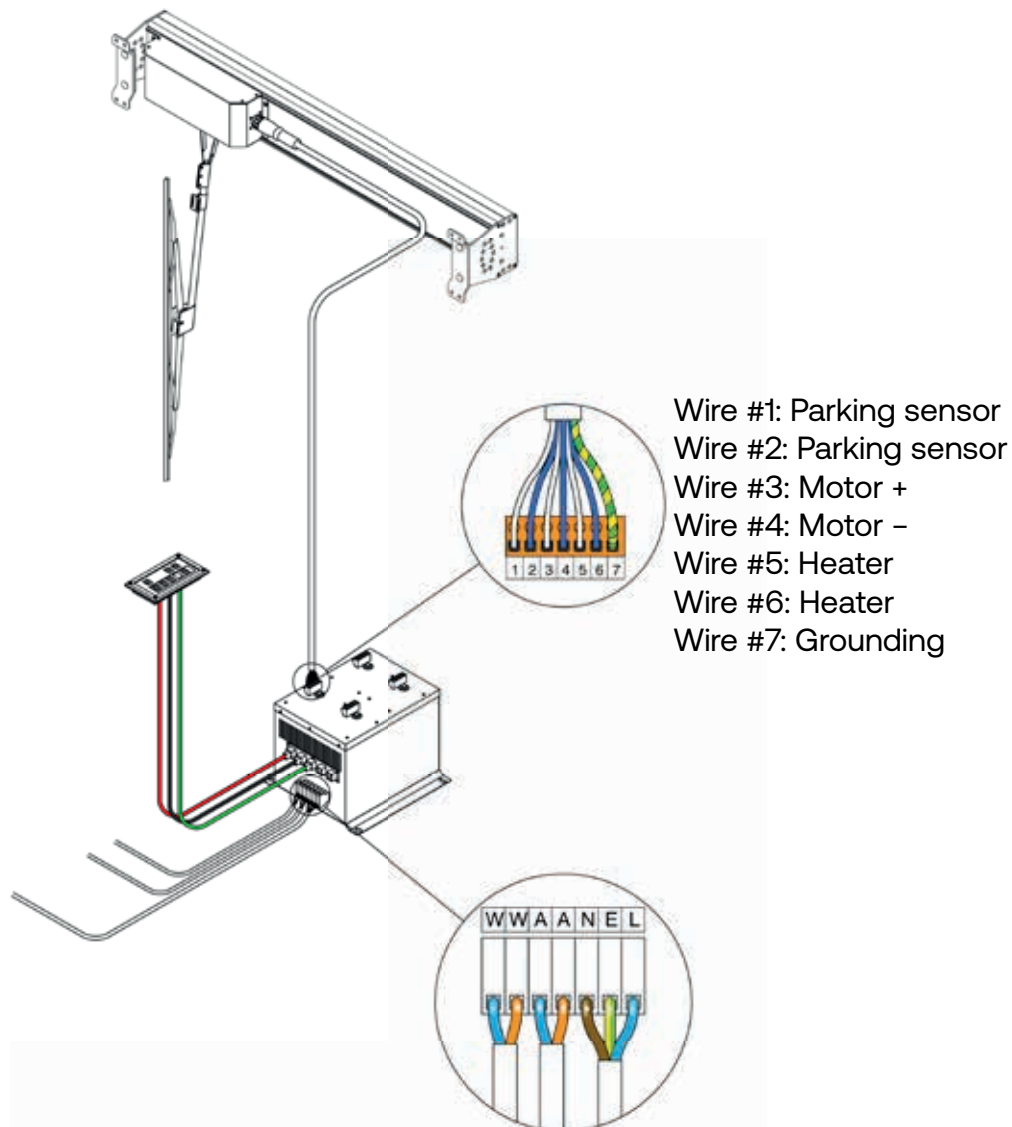

Figure 21 - ECM Cable Connections



Wires #1 to #6 are already connected to different functions inside the wiper unit, and should be connected to the ECM according to the illustration above to function properly.

Cut the cable from the wiper unit to a suitable length, and remove 50 to 100mm of the cable sheath, armour and bedding. For cabinet installations, extra length must be calculated as the screen wires should be terminated in the common cabinet grounding bar. The wiper cable contains four pairs, and each pair is marked with their respective pair number. Remove the plastic coated aluminium tape and separate the pair screens from conductors. Notice that the wires is marked with numbers 1 to 8. Cable pair 4 (pair screen and wires #7 and #8) is not used for this application, and can therefore safely be removed.

Remove 6-8 mm of insulation from each of the 6 wires and install cable crimps. Merge the three pair screens into one common wire using yellow/green tape and cable crimp. Complete the cable preparation using electrical insulation tape on the wire-sheath transition.

5.4.3 Wiper Control Panel

The wiper control panel is connected to the ECM's via two Cat. 5 FTP cables for each wiper group, and one common Cat. 5 FTP cable for the master functions.

DP1 (red), signals for master functions, HEATER, DIMMER and master ON/OFF.

DP2 (black), signals for slave functions, WATER SPRAY, SPEED +/- and group ON/OFF

DP3 (green), signals for the LED display (speed settings 0 to 7).

Cables are normally delivered in a grey colour, colours shown are for illustration purposes only!



Always make sure that power is switched off before doing any kind of maintenance to the electric circuits

The most basic control system consists of a control panel with only one wiper group, connected to a wiper module (ECM). In this case, DP1, DP2 and DP3 on the control panel is connected to DP1, DP2 and DP3 on the wiper module in the same order, as shown in Fig. 22.

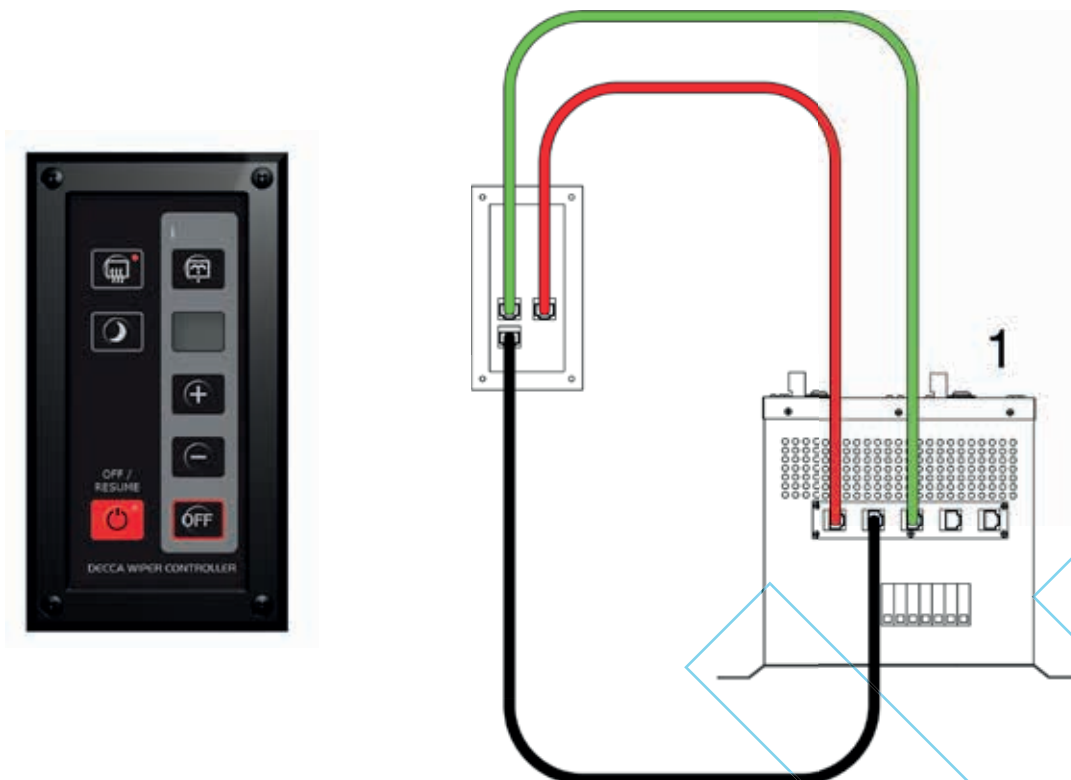

Figure 22 - Wiper Control Panel - ECM Cable Connections, Single group

A slightly more advanced configuration is a control panel with 3 groups, connected to 3 wiper modules. In this case, module #1 passes on the DP1 signal through its “M” output to module #2, and module #2 passes on the DP1 signal to module #3. DP2 and DP3 signals is connected directly to the control panel as shown in Fig. 23.

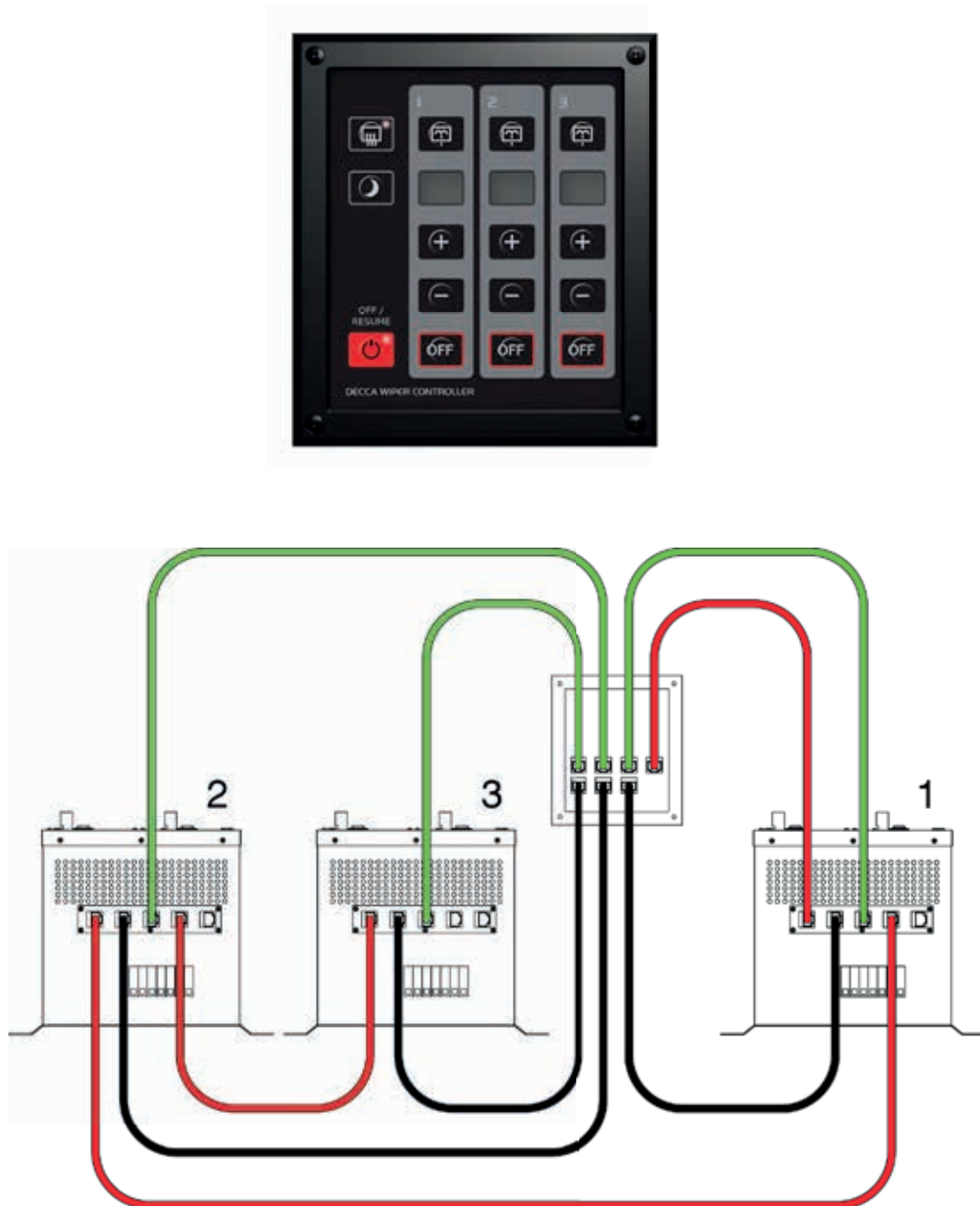

Figure 23 - Wiper Control Panel - ECM Cable Connections, Three Groups

Each wiper module supports up to four wipers. However, it is possible to connect more than four wipers to one wiper group by connecting multiple wiper modules to the same group output on the control panel. This is done by passing on both the DP1 signal (M out) and the DP2 signal (S out). Notice that “slave units” do not utilize the DP3 (display) signal.

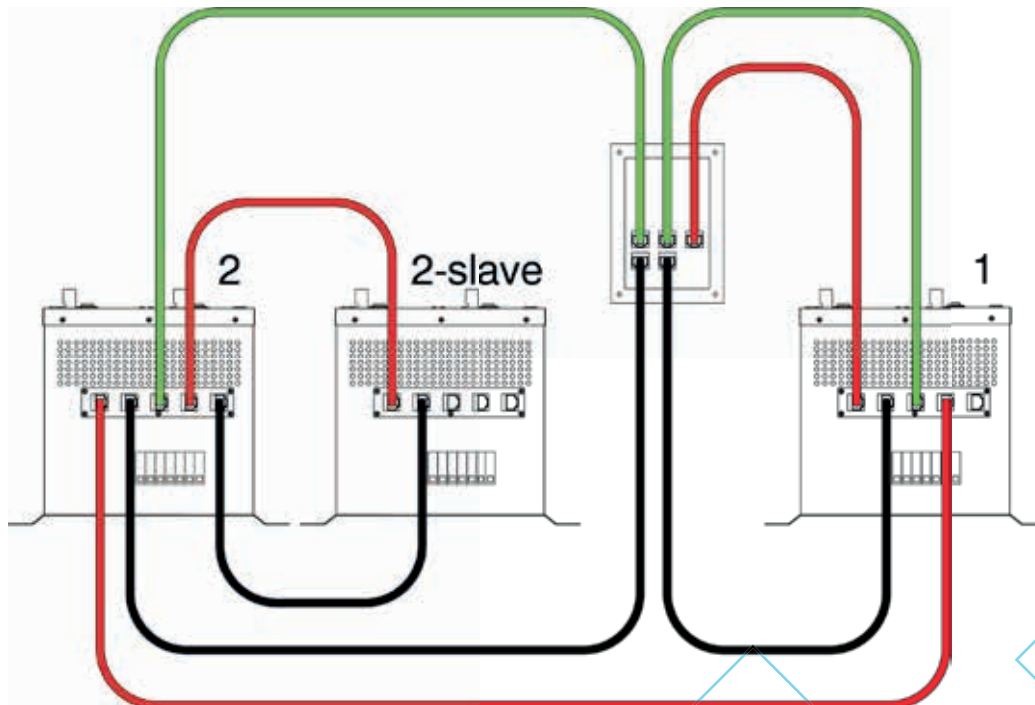

Figure 24 - Wiper Control Panel - ECM Cable Connections, Three Groups (Group 3, slave of group 2)

6 System Operation

6.1 Wiper Control Panel

The control panel operates up to five wiper groups, and up to five water spray zones. Wiper groups (1 - 5) is represented with a column (1 - 5) on the touch panel. Each wiper group can consist of any number of wiper units. Each water spray zone controls a water valve (and an air purge valve where applicable). The three functions shown on the left affect the system as a whole, while the functions in the numbered columns apply to its respective wiper group and water spray zone.

The following commands are valid whether the main switch is in on or off position:

- Heated wiper casing (on/off)
- Night mode (on/off)
- Water spray/air purge

The remaining functions require the control panel to be activated through the main switch. A red LED by the main switch indicates when the system is on/standby mode.



Figure 25 - Wiper Control Panel

6.1.1 Wiper Speed Settings

When the main switch is switched on for the first time after powering up the system, all wiper groups will indicate speed setting 0 (wiper group inactive). Each wiper group is individually controlled using the “speed up” and “speed down” keys, see Fig. 25.

Once a wiper group is activated (speed setting between 1 and 7), it can be deactivated by either stepping down the speed incrementally using the “speed down” key repeatedly, or by pushing the wiper group “OFF” key. The wiper speed settings range from 0 (inactive) to 7, and is indicated below the water spray switch. Speed settings are preset in the following order:

1. Intermittent mode, 15 seconds between sweeps
2. Intermittent mode, 10 seconds between sweeps
3. Intermittent mode, 5 seconds between sweeps
4. Continuous mode, low motor speed
5. Continuous mode, normal motor speed
6. Continuous mode, fast motor speed
7. Continuous mode, extra fast motor speed

6.1.2 Off/Resume Function (Main Switch)

If one or more wiper groups are active as the main switch is turned off, the control system will remember each respective wiper group’s speed setting during standby mode. When the control panel is reactivated (main switch), all wiper groups will resume at their previously used speed settings. By using the off/resume function rather than switching each wiper group off individually, fewer control inputs are required from the operator.

6.1.3 Heater Function

Decca Wipers are equipped with an internal heater element to prevent icing of the moving parts. This function applies to all wiper units whether the wipers are in operation or not, even if the main switch is turned off. When the heater elements are activated, a red LED will illuminate by the heater switch. It is possible to control heated windows from the same switch, but this requires external components that are not included in the standard scope of supply. Please contact your nearest Decca distributor for more information on this option.

6.1.4 Water Spray and Air Purge Function

The Odin control panel features a system for cleaning the windows using pressurised water and air. Push and hold the water spray switch in order to open the water spray valve. The valve will remain open as long as the water spray switch is held down. Releasing the water spray switch will close the water spray valve and open the air purge valve. The air purge lasts for approximately 30 seconds and the wiper units will automatically run at a continuous speed setting during this process.

6.1.5 Night Mode

The night mode function toggles between 100% and 65% LED brightness. The control panel is designed using only LED’s that are in red colour, as this wavelength is perceived to be the least glaring and distracting to the human eye, thereby ensuring good night vision.

7 Spare Parts

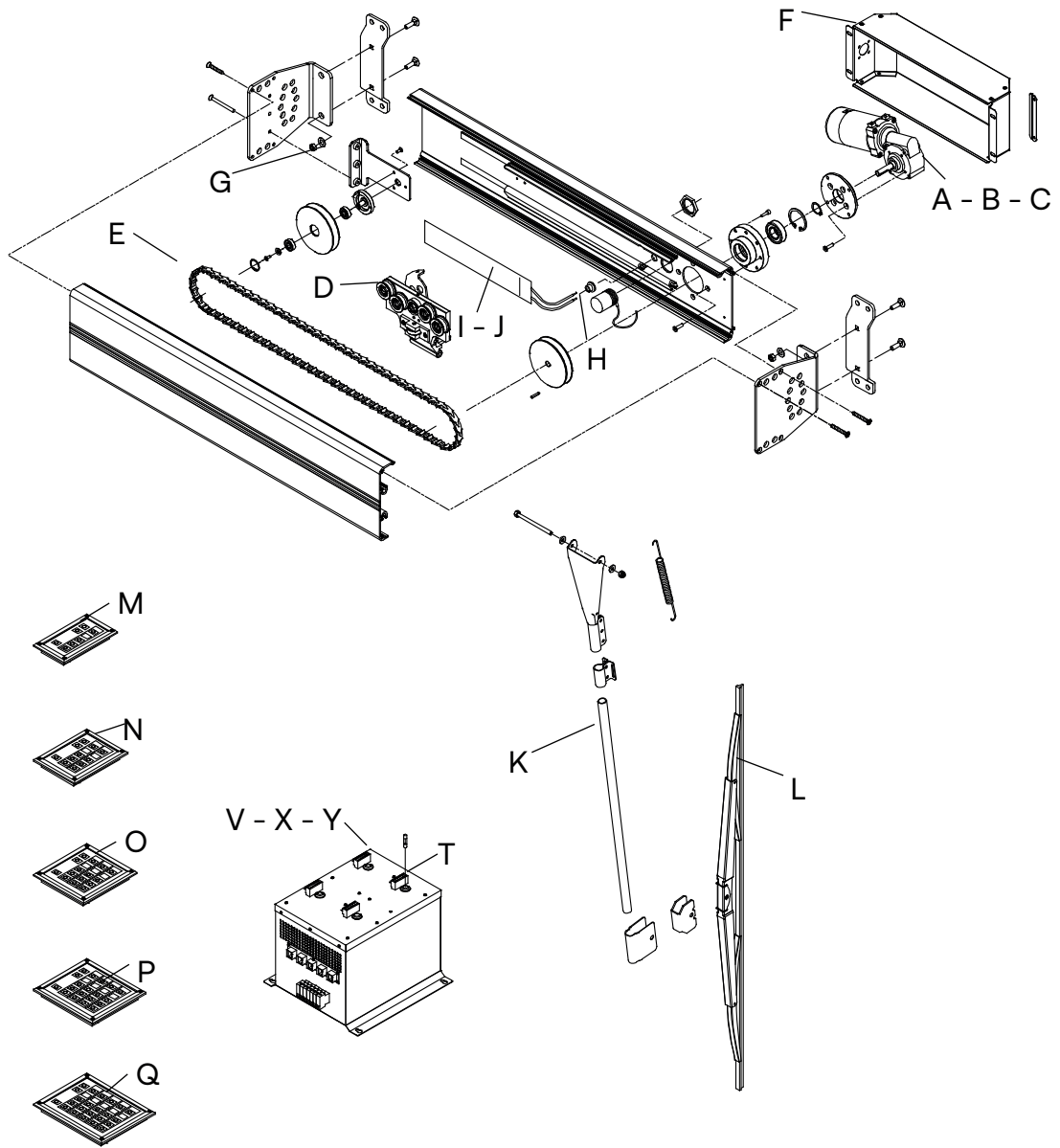

Figure 26 - Spare Parts

Identification	Description	Remarks	Decca No.
	Wiper Unit		
A	Motor Complete PM4 220VAC		81000141
B	Motor Complete PM5 110VAC		81000132
C	Motor Complete PM5 24VDC		81000133
D	Carriage Standard Complete		81000001
E	Drive belt A-profile	Sold by meters	10570105
F	Motorcover With Plug		81000005
G	Drive Belt Tension Bracket		81000022
H	Parksensor NBN15-30GM40-ZO/ 088214	220V and 110V	50102001
I	Heater tape 250mm single 50W 220VAC		50103111
J	Heater tape 250mm single 50W 110VAC		50103112
	Heater tape 250mm single 50W 24VDC		50103113
	Wiper Arms and Blades		
K	Wiper Arm (50-70cm blade)max L-arm=730mm		81000007
K1	Wiper Arm (80-120cm blade)max L-arm=730mm		81000008
	Wiper Wiper arm XL, adjustable - max L-arm=880mm		81000025
L1	Wiper Blade 500 mm		10500500
L2	Wiper Blade 600mm		10500600
L3	Wiper Blade 700 mm		10500700
L4	Wiper Blade 800mm (16 mm fixing)		10500800
L4.1	Wiper Blade 800mm (21 mm fixing)		10500801
L5	Wiper Blade 900mm		10500901
L6	Wiper Blade 1000mm		10501001
	Wiper Blade 1200mm		10501201
	All blades: Min. 400mm to Max. 1200 mm		
	16 mm fixing from 400mm to 800mm blades		
	21 mm fixing from 800 mm blades and up		
	Control Panels		
M	Odin Control Panel for 1 Group		12183010
N	Odin Control Panel for 2 Group		12183020
O	Odin Control Panel for 3 Groups		12183030
P	Odin Control Panel for 4 Groups		12183040
Q	Odin Control Panel for 5 Groups		12183050
	Electronic Control Unit		
T1	Odin Electronic Control Unit for 1 Group 220V		12190011
T2	Odin Electronic Control Unit for 2 Groups 220V		12190021
T3	Odin Electronic Control Unit for 3 Groups 220V		12190031
T4	Odin Electronic Control Unit for 4 Groups 220V		12190041
T5	Odin Electronic Control Unit for 1 Group 110V		12190012
T6	Odin Electronic Control Unit for 2 Groups 110V		12190222
T7	Odin Electronic Control Unit for 3 Groups 110V		12190032
T8	Odin Electronic Control Unit for 4 Groups 110V		12190042
	Other parts		
U	Patch splitter 1xRJ45F - 2xRJ45F		50400001
V	Fuse TR5 1,25A Time Delay, 220VAC		50508012
X	Fuse TR5 1,6A Time Delay, 110VAC		50508008
Y	Fuse TR5 5A Time Delay, 24VDC		50508013
	Cable w/connector 5 MTR		81000205
	Cable w/connector 10 MTR		81000210
	Cables W Conn. can be delivered in tailored lengths		

8 Warranty

Standard warranty is 12 month from delivery from shipyard to ship owner, or 24 months from delivery to shipyard, whichever comes first.

Wiper blades are not covered by the warranty.

9 Trouble shooting

Trouble shooting ODIN module:

1. Check LED's inside the module.
If no LED is lit - Main PCB defector no voltage from main fuse
2. Turn off main fuse for wiper cabinet and pull out plug from wiper before measuring
3. Test Fuse TR5 on ODIN module
4. Measure resistance between:

Pin 1-2, normal 12-20 MOhm	Park sensor
Pin 3-4, normal 16-50 Ohm	Motor +/-
Pin 5-6, normal 150 Ohm-1 KOhm	Heater
5. Measure resistance between:

Pin 3-4 and ground	Normal infinite
Pin 5-6 and ground	Normal infinite

All values normal and Wiper does not work:

Motor card defect

Resistance between Pin 1 and 2 lower than 10 MOhm (Wiper doesn't park):

Parking sensor defect

Resistance between Pin 3 and Pin 4 not between 16 Ohm and 50 Ohm:

Motor defect

Resistance between Pin 3 and Ground, Pin 4 and Ground, Pin 5 and Ground or Pin 6 and Ground is NOT infinite:

Wiperplug on Wiper defect or cables inside motorcover defect

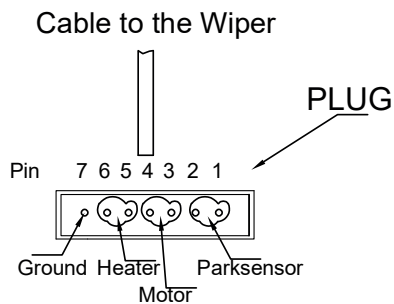
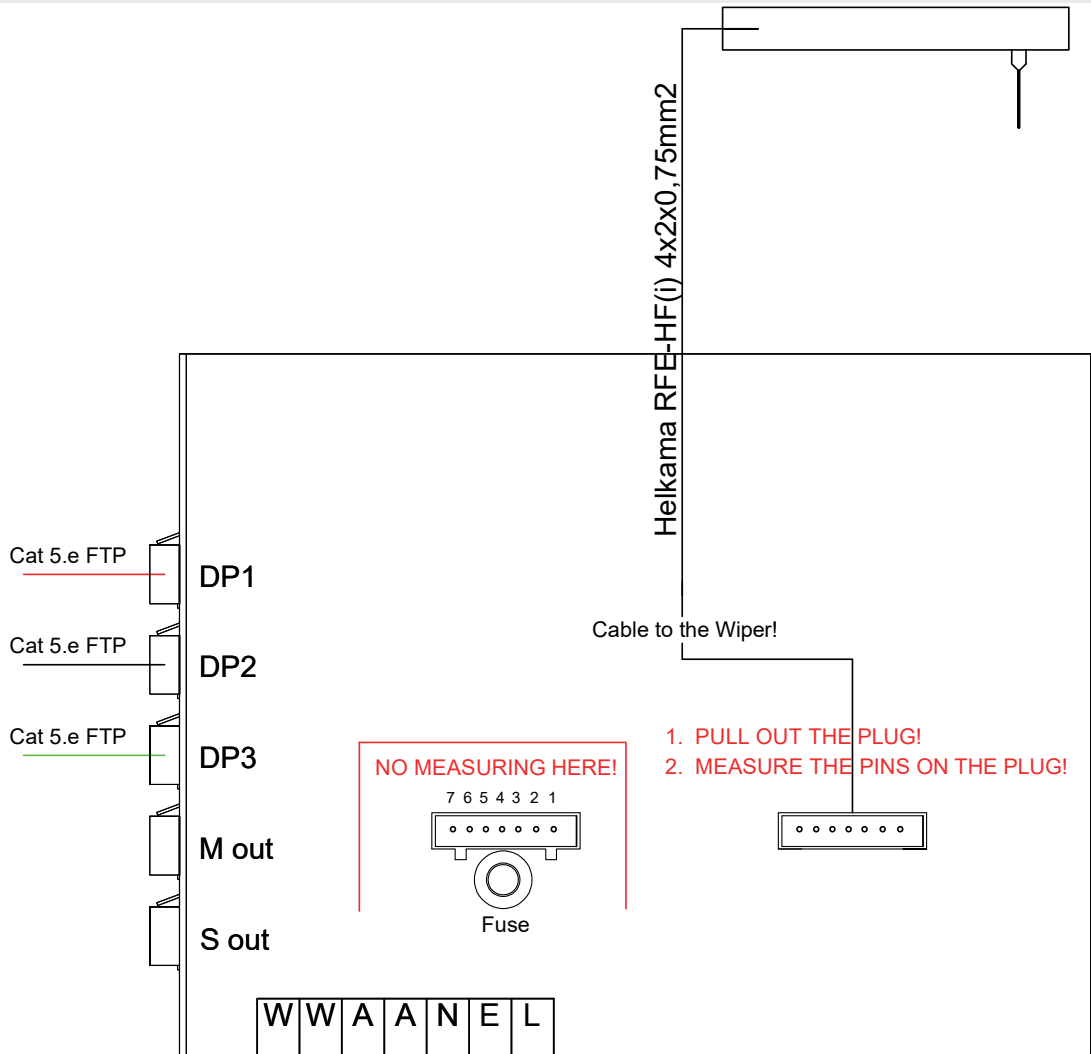

- Pin 1 and Pin 2 : Parksensor (ca. 1.1 MOhm)
- Pin 3 and Pin 4 : Motor (ca. 15-50Ohm)
- Pin 5 and Pin 6 : Heater (ca. 150Ohm-1KOhm)

Pin 3 / 4 and Ground infinity!
 Pin 5 / 6 and Ground infinity!

Contact

Idrettsvegen 113C
5353 Straume
NO - Norway

Phone No.
+47 551 12 300

Website
deccawiper.com

Email
sales@deccawiper.com

Australia:

STELA MARINE GROUP

Phone No +61 7 5665 8071
info@stellamarine.com.au
www.stellamarine.com.au

China:

HOLYLIGHT (HK) TRADING CO. LTD

Phone No +852 25 437 048
anthony@holylight.biz
www.hollylight.biz

India:

MOLOOBHOY MARINE

Phone No +9122 23 080 800
info@moloobhoyme.com
www.moloobhoyme.com

Singapore & Asean region:

ALQUEST

Phone No +65 6749 9359
sales@alquest.com.sg
www.alquest.com.sg

Spain:

CONAVI S.L

Phone No +34 886 124 607
juancarlos@conavi.es
www.conavi.es

South Africa:

SEASCAPE MARINE SERVICES

Phone No +27 215 118 201
info@seascapemarine.co.za
www.seascapemarine.co.za

UK & The Netherlands:

EXALTO WIPER TECHNOLOGIES

Phone No +31 85 203 17 00
wipers@exalto.com
www.exaltowipers.com

USA:

IMTRA CORPORATION

Phone No +1 508 9957 000
decca@imtra.com
www.imtra.com

Rest of the World:

EXALTO DECCA WIPER
TECHNOLOGIES.

Phone No +47 551 12 300
sales@deccawiper.com
www.deccawiper.com